

TWO POST LIFT
MM Superlift 4000B (007935018165)
INSTRUCTION & MAINTENANCE MANUAL

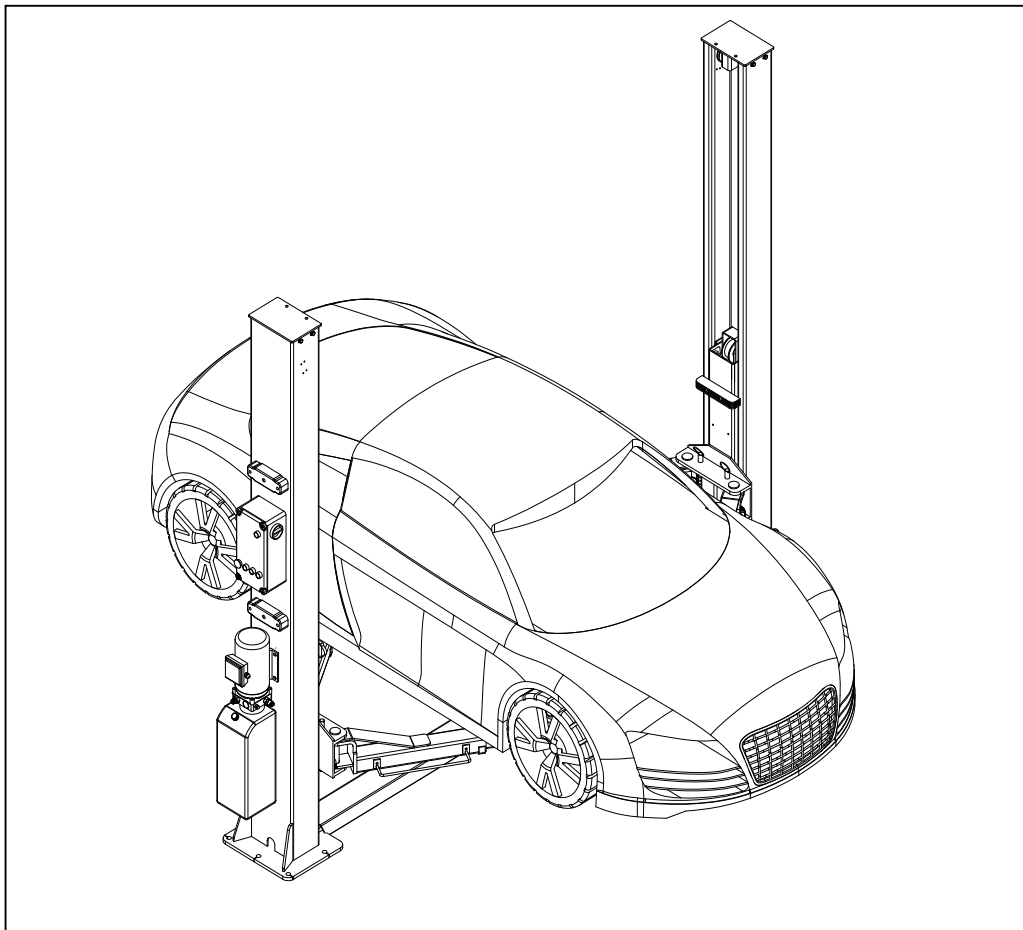

Two Post Lift with floor plate

Electric release

Lifting Capacity: 4000KG



INDEX

1. Important safety instructions.....	3~4
1.1 Important notices	
1.2 Qualified personnel	
1.3 Danger notices	
1.4 Training	
1.5 Warning signs	
2. Overview of the lift.....	5
2.1 General descriptions	
2.2 Technical data	
2.3 Construction of the lift	
3. Installation instructions.....	6~12
3.1 Preparations before installation	
3.2 Precautions for installation	
3.3 Installation	
3.4 Items to be checked after installation	
4. Operation instructions.....	13~14
4.1 Precautions	
4.2 Flow chart for operation	
4.3 Operation instructions	
5. Trouble shooting.....	14
6. Maintenance.....	15
7. Annex.....	16~24
Annex1, Overall diagram	
Annex2, Hydraulic working system	
Annex3, Wire connection diagram of lock electromagnet	
Annex4, Wiring diagram	
Annex5, Assembly drawings	

IMPORTANT SAFETY INSTRUCTIONS

1.1 Important notices

we will offer one-year's quality warranty for the whole machine, during which any quality problem will be properly solved to the user's satisfaction. However, we will not take any responsibility for whatever bad consequence resulted from improper installation and operation, overload running or unqualified ground condition.

This 2-posts lift is specially designed for lifting motor vehicles that weighs within its outmost lifting capacity. Users are not allowed to use it for any other purposes. Otherwise, we, as well as our sales agency, will not bear any responsibility for accidents or damages of the lift. Make sure to pay careful attention to the label of the lifting capacity attached on the lift and never try to lift cars with its weight beyond.

Read this manual carefully before operating the machine so as to avoid economic loss or personnel casualty incurred by wrong operation. Without professional advice, users are not permitted to make any modification to the control unit or whatever mechanical unit.

1.2 Qualified personnel

1.2.1 Only these qualified staff, who have been properly trained, can operate the lift.

1.2.2 Electrical connection must be done by a competent electrician.

1.2.3 People who are not concerned are not allowed in the lifting area.

1.3 Danger notices

1.3.1 Do not install the lift on any asphalt surface.

1.3.2 Read and understand all safety warnings before operating the lift.

1.3.3 The lift, if is not specially designed upon customer's request, is not fit for outdoor use.

1.3.4 Keep hands and feet away from any moving parts. Keep feet clear of the lift when lowering.

1.3.5 Only these qualified people, who have been properly trained, can operate the lift.

1.3.6 Do not wear unfit clothes such as large clothes with flounces, tires, etc, which could be caught by moving parts of the lift.

1.3.7 To prevent evitable incidents, surrounding areas of the lift must be tidy and with nothing unconcerned.

1.3.8 The lift is simply designed to lift the entire body of vehicles, with its maximum weight within the lifting capacity.

1.3.9 Always insure the safety latches are engaged before any attempt to work near or under the vehicle.

1.3.10 Make sure to place the lifting pads to the positions as suggested by vehicle makers and when gradually lift the vehicle to the desired height, operators should be certain that the vehicle will not slant, roll-over or slide in lifting process.

1.3.11 Check at any time the parts the lift to ensure the agility of moving parts and the performance of synchronization. Ensure regular maintenance and if anything abnormal occurs, stop using the lift immediately and contact our dealers for help.

1.3.12 Lower the lift to its lowest position and do remember to cut off the power source when service finishes.

1.3.13 Do not modify any parts of the lift without manufacturer's advice.

1.3.14 If the lift is going to left used for a long time, users are required to:

- a. Disconnect the power source;
- b. Empty the oil tank;
- c. Lubricate the moving parts with hydraulic oil.

1.4 Training

Only these qualified people, who have been properly trained, can operate the lift. We are quite willing to provide professional

training for the users when necessary.

Attention: For environment protection, please dispose the disused oil in a proper way.

1.5 Warning signs

All safety warning signs attached on the machine are for the purpose of drawing the user's attention to safety operation. The labels must be kept clean and need to be replaced when they are worn-out or have dropped. Read the explanations of the labels carefully and try to memorize them.

<p>ATTENTION</p> <p>The presence of persons (during lifting or lowering) underneath the lift is forbidden!</p>	<p>ATTENTION</p> <p>Keep emergency exits clear!</p>	<p>ATTENTION</p> <p>Repairs by qualified personnel only!</p>	<p>ATTENTION</p> <p>Avoid strong shaking of the vehicle!</p>
<p>ATTENTION</p> <p>Always use only one adapter per arm. Distribute the weight of the vehicle evenly on the four arms!</p>	<p>ATTENTION</p> <p>Pay attention to your feet while lowering the lift!</p>	<p>ATTENTION</p> <p>Usage of the lift by qualified personnel only!</p>	<p>ATTENTION</p> <p>Only qualified personnel allowed within the lift area!</p>
<p>ATTENTION</p> <p>Please pay attention to the manufacturers fixing points!</p>	<p>ATTENTION</p> <p>Safety restraints are to be used during lifting of heavy loads!</p>		
<p>ATTENTION</p> <p>Use adapter (one per sensor) to ensure a better grip. Check if the transporter adapter is positioned correctly!</p>	<p>ATTENTION</p> <p>Do not overload the lift! The usage of other objects between the sensor and motor vehicle are prohibited!</p>		

OVERVIEW OF THE LIFT

2.1 General descriptions

This floor plate two posts lift is composed of posts, carriages, lifting arms, cylinders and motor unit, etc.

It is driven by an electro-hydraulic system. The gear pump delivers hydraulic oil to oil cylinders and pushes upwards its piston. The piston drives the chain to raise the carriage and the lifting arms. During lifting process,

the safety latch will automatically and firmly bite with the safety teeth block in the posts. Therefore, no slipping will happen in case the hydraulic system breaks down.

Safety structure

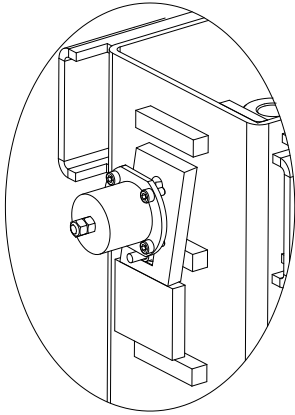

2.2 Technical data

Model	Lifting capacity	Full rise time	Full rise	Height	Width	Inside columns
Two post lift	4000kg	50s	1930mm	2824mm	3365mm	2780mm

2.3 Construction of the lift

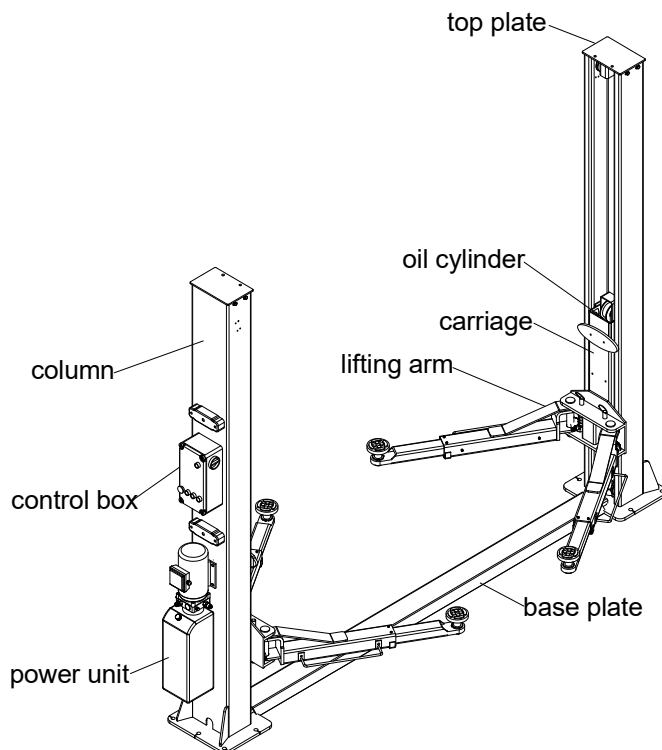

INSTALLATION INSTRUCTIONS

3.1 Preparations before installation

3.1.1 Tools and equipments needed

- ✓ Appropriate lifting equipment
- ✓ Anti-abrasion hydraulic oil.
- ✓ Rotary Hammer Drill with 3/4" drill bit.
- ✓ Chalk and tape measure, magnetic plump, 8 meters $\Phi 15$ level pipe.
- ✓ Sockets and open wrenches, a set of inside hex wrenches, cross and straight screw drivers.
- ✓ Hammer, 4pounds, sharp nose pliers, $\Phi 17, \Phi 19, \Phi 22$ socket spanners.

3.1.2 List for parts checking ---Annex 1 (Packing list)

Unfold the package and check if any parts missed as per Annex 1. Do not hesitate to contact us in case any parts missed, but if you do not contact us and insist installing upon the lack of some parts, well as our dealers will not bear any responsibility for this and will charge for any parts subsequently demanded by the buyer.

3.1.3 Ground conditions

The lift should be fixed on a smooth and solid concrete ground with its strength more than 3000psi, tolerance of flatness less than 5mm and minimum thickness of 200mm. In addition, newly built concrete ground must undergo more than 28days' cure and reinforcement.

3.2 Precautions for installation

3.2.1 Make sure the two posts stand paralleled and are vertical to the ground. No slanting.

3.2.2 Joints of oil hose and steel cable must be firmly connected in order to avoid the looseness of steel cable and leakage of oil hose.

3.2.3 All bolts should be firmly screwed up.

3.2.4 Do not place any vehicle on the lift in the case of trial running.

3.3 Installation

Step 1: Remove the packaging, take out the carton for accessories and cover plate.

Step 2: Firstly, put something supporting between the two posts or suspend one of the posts by a crane and then remove the bolts on the package.

Attention: Please pay special attention not to let the post fall down for it may cause casualty or bring damages to the accessories fixed in the post.

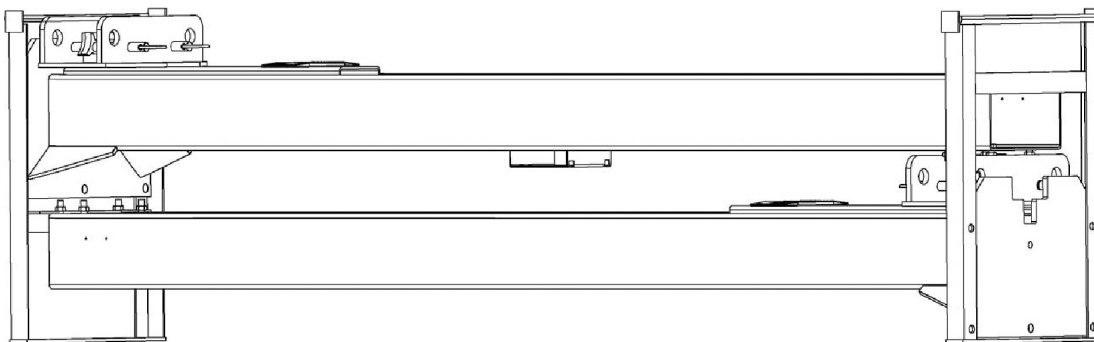

Step3: When the first post has been taken away, place something supporter under the second post and then remove the bolts on the package.

Step 4: Fix the standing position for the two posts. (See Annex 3, floor plan)

1. Unfold the package and decide on which post the power unit will be mounted.
2. Draw an outline of the base plate on the ground with chalk and ascertain the position for the post.

Step 5: Erect the posts, power side post first and then the other post.

1. Drill anchor holes for expansion bolts on the ground with an electrical drill. Make sure to drill vertically.
2. After holes have been drilled, remove thoroughly the debris and dust in them and ascertain that the posts stay upon the circle previously drawn by chalk.

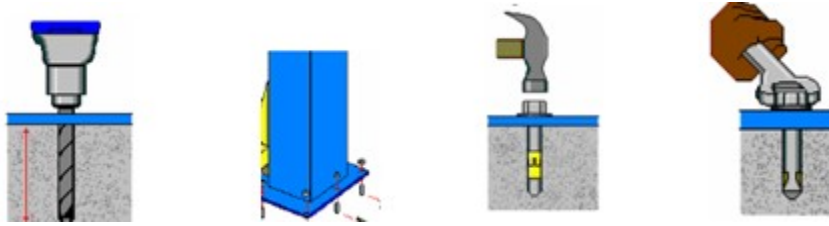

Step6: Connect steel cables.

1. Route and fix according to the following diagram of steel cable connection.
2. Raise carriages on both sides approximately 800mm above the ground. Carriages must be on the same height from the floor.
3. Make sure that the mechanical safety locks in each post are fully engaged before attempting to route cables.
4. After the cable being fixed, adjust and make the cable at both sides be with the same tightness which could be judged by the sound emitted during lifting process. Make judge and adjustment after trial running.
5. Grease after being fixed. (It is a must.)

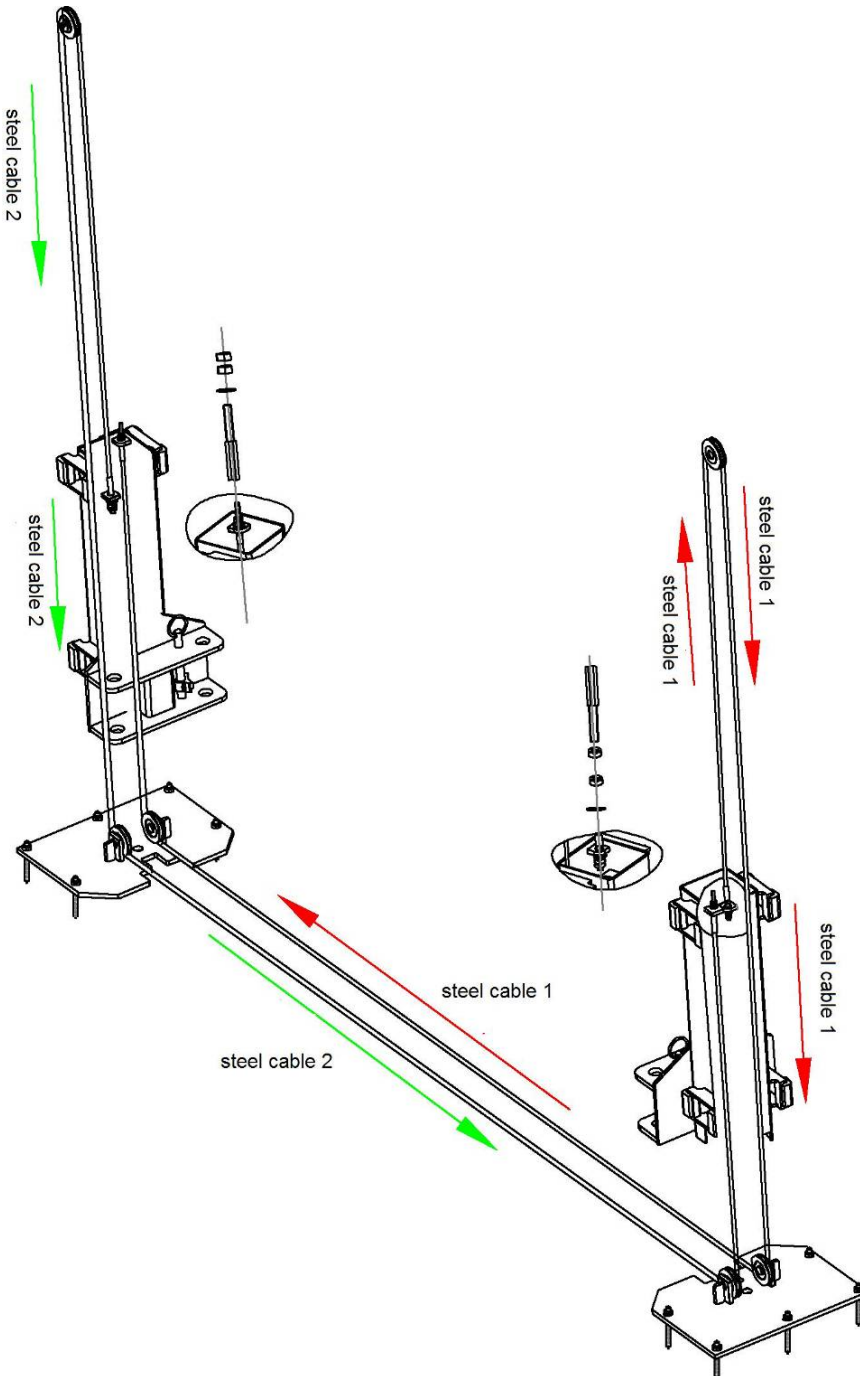

Step7: Mount the power unit onto the power side post.

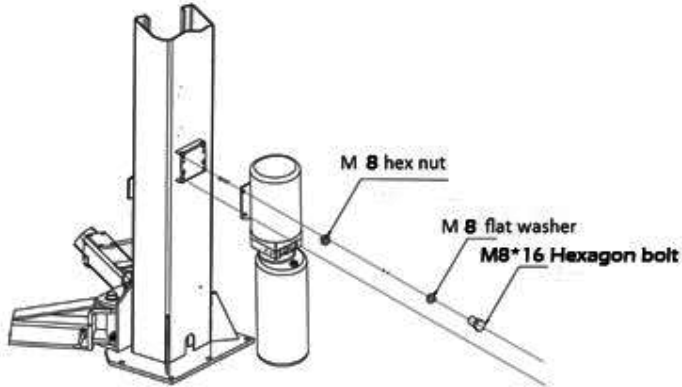

Step8: Connect oil hoses.

Connect the oil hose as per the following diagram.

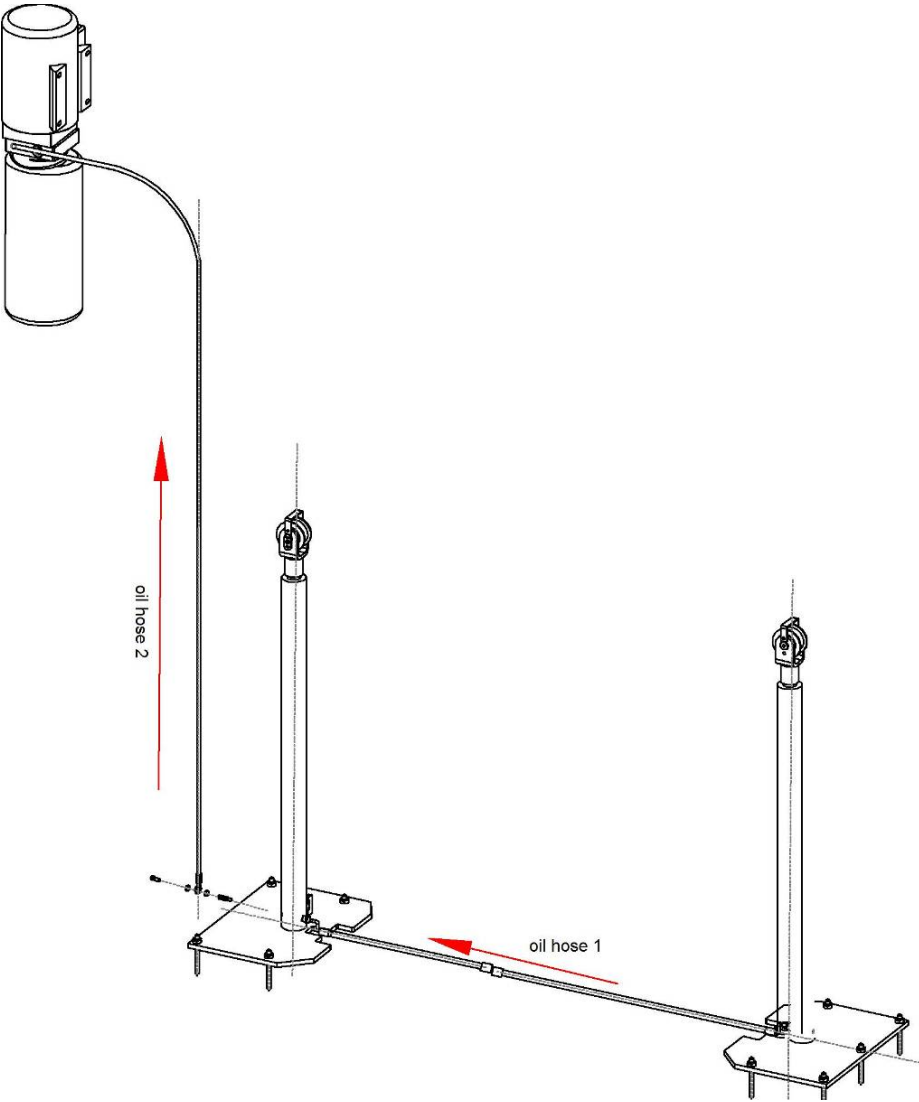

Step8: Connect wires.

1. Mount the control box on to the power side post.

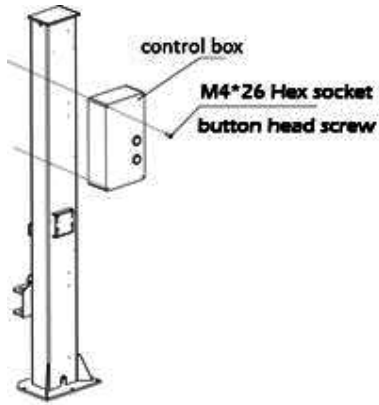

2. Fix the limit switch into the power side post.

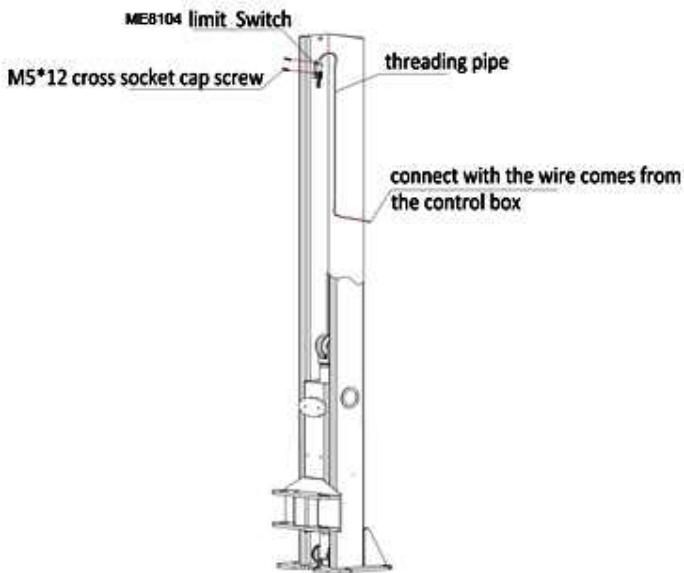

3. Connect the wire of down electromagnet, lock electromagnet and limit switch

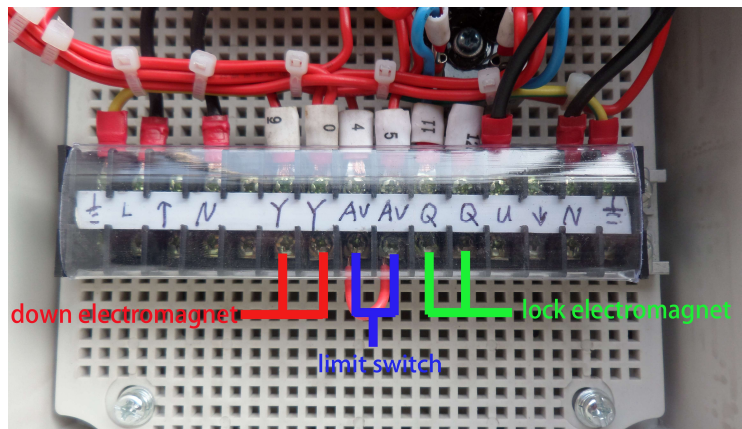
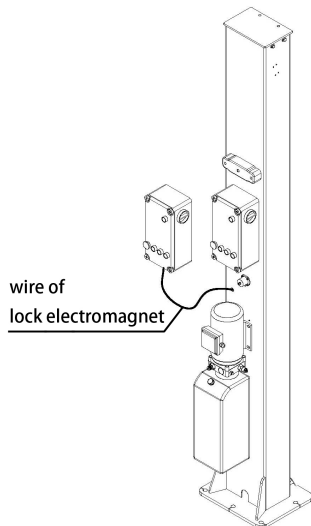

4. Connect the motor wire

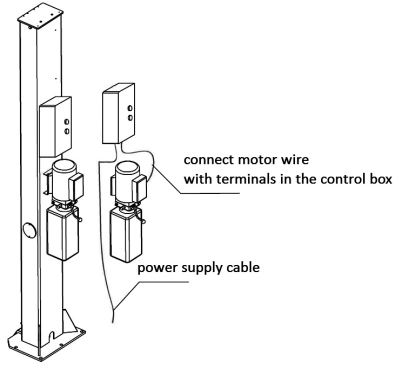

Step9: Install lifting arms.

Connect the lifting arm and the carriage by shafts.

Install the lifting arms onto the carriages and ensure the arm lock could work.

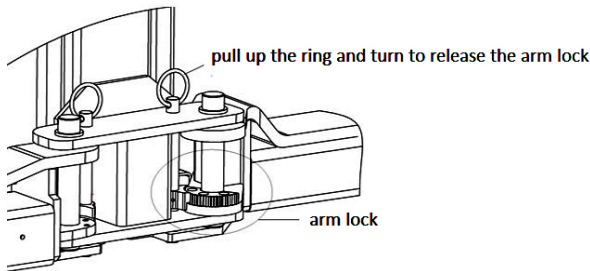

Step10: Fill with hydraulic oil.

The volume of oil tank is 10L.To insure the lift work normally, the amount of oil in it should at least reach 80% of the tank's total volume.

32#anti-abrasion hydraulic oil for winter, 46# for summer.

Step11: Trial running.

1. Do refer to the operation instructions in advance and keep in mind that no vehicle left on the lift in the process of trial running.
2. Check and ensure all the connections are in good condition.
3. No vehicle on the lift during trial running.

3.4 Items to be checked after installation.

S/N	Check items	YES	NO
1	Are the posts vertical to the floor?		
2	Are the two posts paralleled?		
3	Is the oil hose well connected?		
4	Is the steel cable well connected?		
5	Are all lifting arms well fixed?		
6	Are electrical connections right?		
7	Are the rest joints firmly screwed?		
8	Are all items need lubricating added with grease?		

OPERATION INSTRUCTIONS

4.1 Precautions

4.1.1 Check all the joints of oil hose. Only when there is no leakage, the lift can start work.

4.1.2 The lift, if its safety device malfunctions, shall not be used.

4.1.3 The machine shall not lift or lower an automobile if its center of gravity is not positioned midway of the swing arms. Otherwise, the we as well as our dealers will not bear any responsibility for any consequence resulted thereby.

4.1.4 Operators and other personnel concerned should stand in a safety area during lifting and lowering process.

4.1.5 When lifting arms rise to the desired height, switch off the power at once to prevent any mal-operation done by unconcerned people.

4.1.6. Make sure the safety lock of the lift is engaged before start working under the vehicle and no people under the vehicle during lifting and lowering process.

4.2 Flow chart for operation

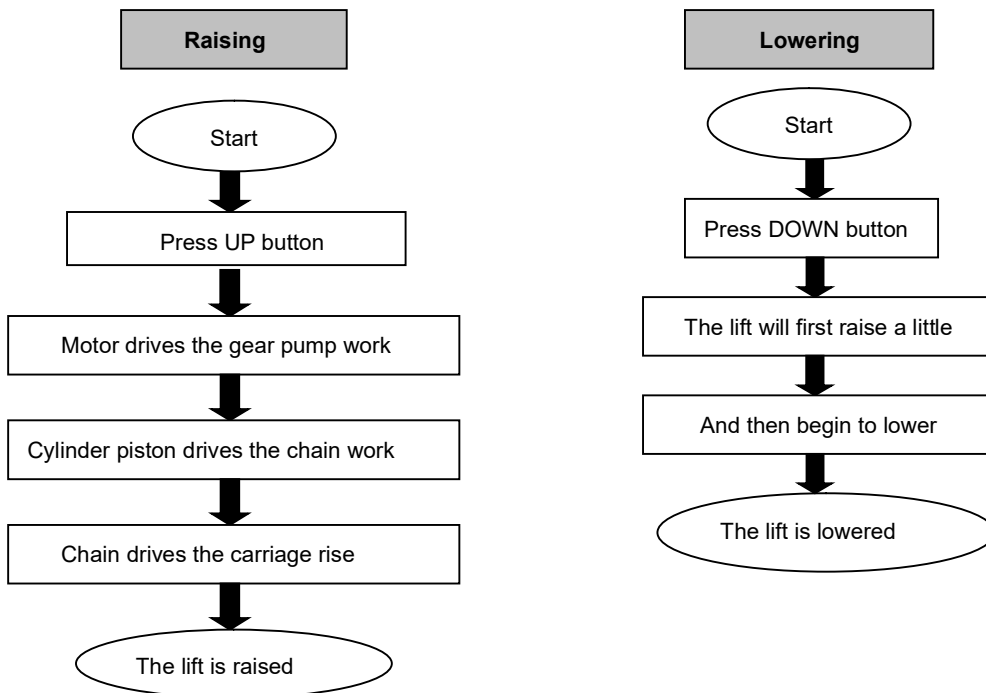

4.3 Operation instructions



Raise the lift

1. Make sure that you have read and understood the operation manual before operation.
2. Park the vehicle between two posts.
3. Adjust the lifting arms until they reach the supporting positions of the vehicle and make sure the gravity of vehicle located in the center of four lifting arms.
4. Connect the power supply as per requirements on the nameplate attached, and switch on.
5. Press the "UP" button on the control box until pads of lifting arms touched the prop-position of vehicle.
6. Keep on raising the vehicle to let it have a bit clearance from the ground and check again its stability.
7. Raise the vehicle to the desired height, check it is safe or not, press the "unlocking handle" button to have the safety locks engaged, and then perform maintenance or repair work underneath.

Lock the lift (Fig 12)

1. Press the "LOCK" button to lock the carriage.

Lower the lift

2. Press the "DOWN" button on the control box to.
3. The lift will first raise a little, and then begin to lower.
4. After the lifting arms lower to the lowest position, pull them out from under the vehicle and clear up all the obstacles.
5. Drive the vehicle away.

Emergency stop

For any emergency, please press the "EMERGENCY STOP" to stop operation.

TROUBLE SHOOTING

ATTENTION: If the trouble could not be fixed by yourself, please do not hesitate to contact us for help. We will offer our service at the earliest time we can. By the way, troubles could be judged and solved much faster if more details or pictures could be provided.

TROUBLES	CAUSE	SOLUTION
Abnormal noise	Abrasion exists on insider surface of the posts.	Grease the inside of the post.
	Trash in the post.	Clear the trash
Motor does not run and will not rise	The wire connection is loose.	Check and make a good connection.
	The motor is blown.	Replace it.
	The limit switch is damaged or the wire connection is loose.	Connect it or adjust or replace the limit switch.
Motor runs but will not raise	The motor run reversely.	Check the wire connection.
	Overflow valve is loose or jammed.	Clean or adjust it.
	The gear pump is damaged.	Replace it.
	Oil level is too low.	Add oil.
	The oil hose became loose or dropped off.	Tighten it.
	The cushion valve became loose or jammed.	Clean or adjusts it.
Carriages go down slowly after being raised	The oil hose leaks.	Check or replace it.
	The oil cylinder is not tightened.	Replace the seal.
	The single valve leaks.	Clean or replace it.
	Solenoid valve fails to work well.	Clean or replace it.
	Steel cable is loose or not with same tightness.	Check and adjust the tightness.
Raising too slow	The oil filter is jammed.	Clean or replace it.
	Oil level is too low.	Add oil.
	The overflow valve is not adjusted to the right position.	Adjust it.
	The hydraulic oil is too hot (above 45°) .	Change the oil.
	The seal of the cylinder is abraded.	Replace the seal.
	Inside surface of the posts is not well greased.	Add grease.
Lowering too slow	The throttle valve jammed.	Clean or replace.
	The hydraulic oil is dirty.	Change the oil.
	The anti-surge valve jammed.	Clean it.
	The oil hose jammed.	Replace it.
The steel cable is abraded	No grease when installation or out of lifetime.	Replace it.

MAINTENANCE

Easy and low cost routine maintenance can ensure the lift work normally and safely. Following are requirements for routine maintenance. Frequency of routine maintenance is determined by working condition and frequency.

THE FOLLOWING PARTS ARE NEEDED TO BE LUBRICATED

S/N	Description
1	Up pulley
2	Steel cable
3	Chain wheel
4	Chain
5	Sliding block
6	Pin
7	Arm block
8	Lifting arm
9	Lifting tray
10	Down pulley

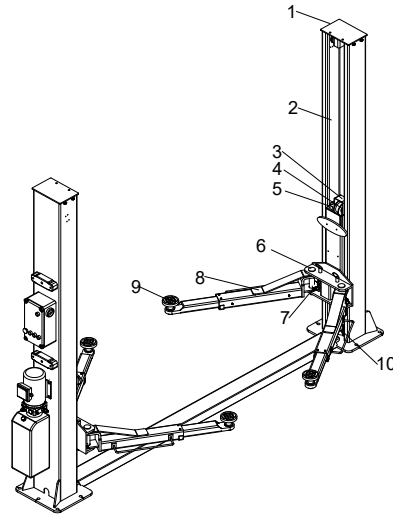

6.1 Daily checking items before operation

The user must perform daily check. Daily check of safety lock system is very important – the discovery of device failure before action could save time and prevent great loss, injury or casualty.

- Before operation, judge whether the safety locks are engaged by sound.
- Check whether oil hose well connected and whether it leaks or not.
- Check the connections of chain and steel cable and check the power unit.
- Check whether expansion bolts are firmly screwed.
- Check if arm lock works well or not.

6.2 Weekly checking items

- Check the flexibility of moving parts.
- Check the working conditions of safety parts.
- Check the amount of oil left in the oil tank. Oil is enough if the carriage can be raised to highest position. Otherwise, oil is insufficient.
- Check whether expansion bolts are firmly screwed.

6.3 Monthly checking items

- Check whether expansion bolts are firmly screwed.
- Check the tightness of the hydraulic system and screw firm the joints if it leaks.
- Check the lubrication and abrasion circumstance of axial pins, carriages, lifting arms and other related parts and replace in time with new ones if they failed to work well.
- Check the lubrication and abrasion circumstance of steel cable.

6.4 Yearly checking items

- Empty the oil tank and check the quality of hydraulic oil.
- Wash and clean the oil filter.

If users strictly follow the above maintenance requirements, the lift will keep in a good working condition and meanwhile accidents could be avoided to a large extent.

Annex1, Overall diagram

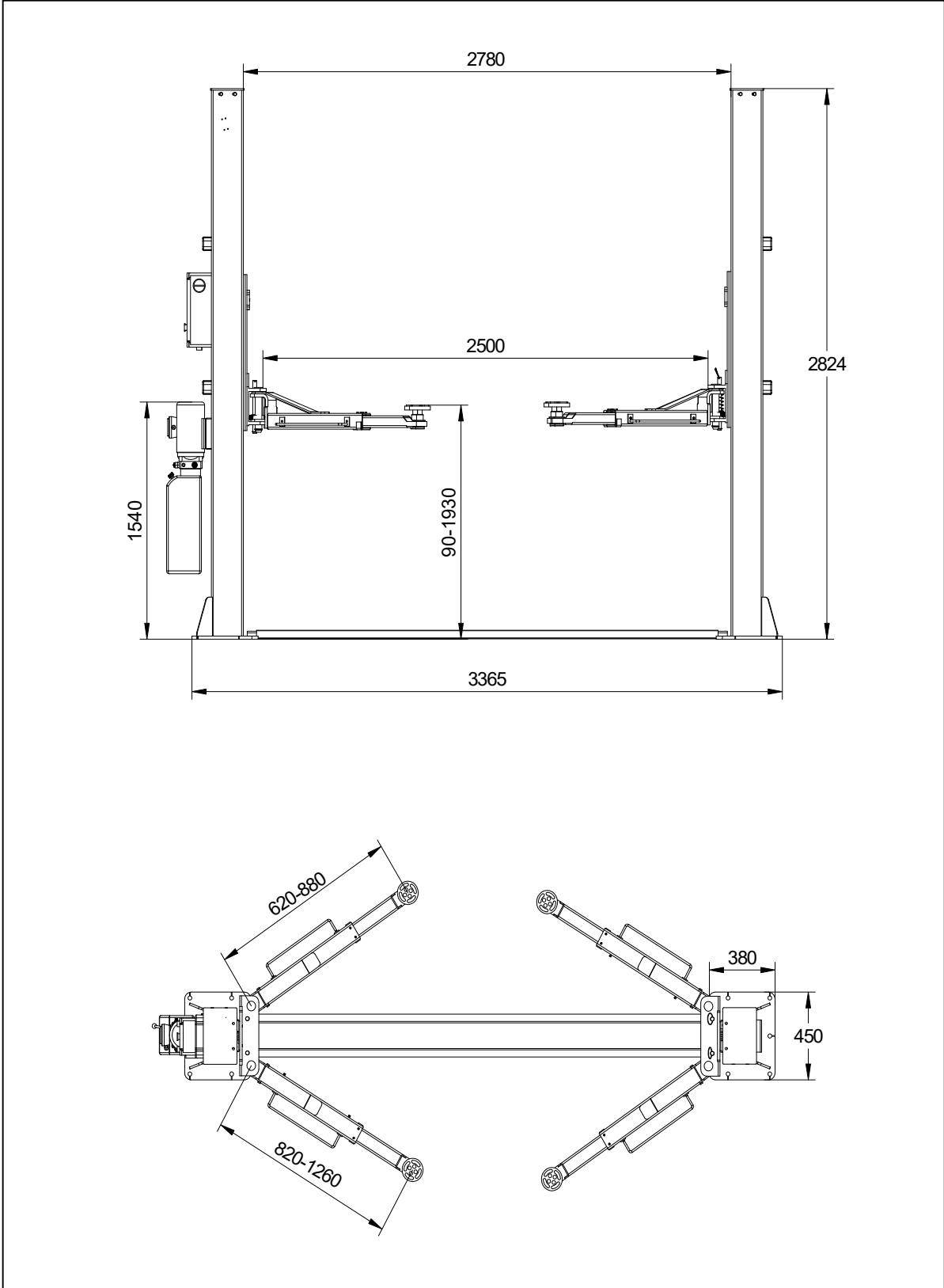

Annex 2, Hydraulic working system

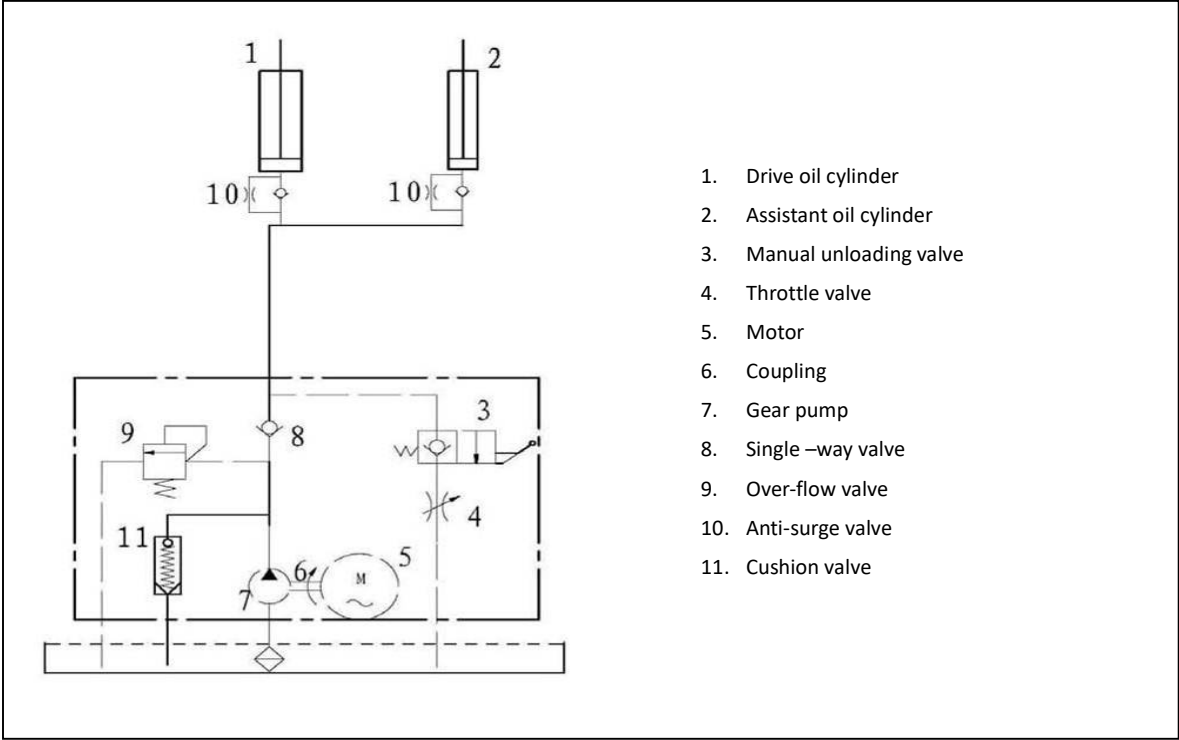

Annex 3, Wire connection diagram of lock electromagnet

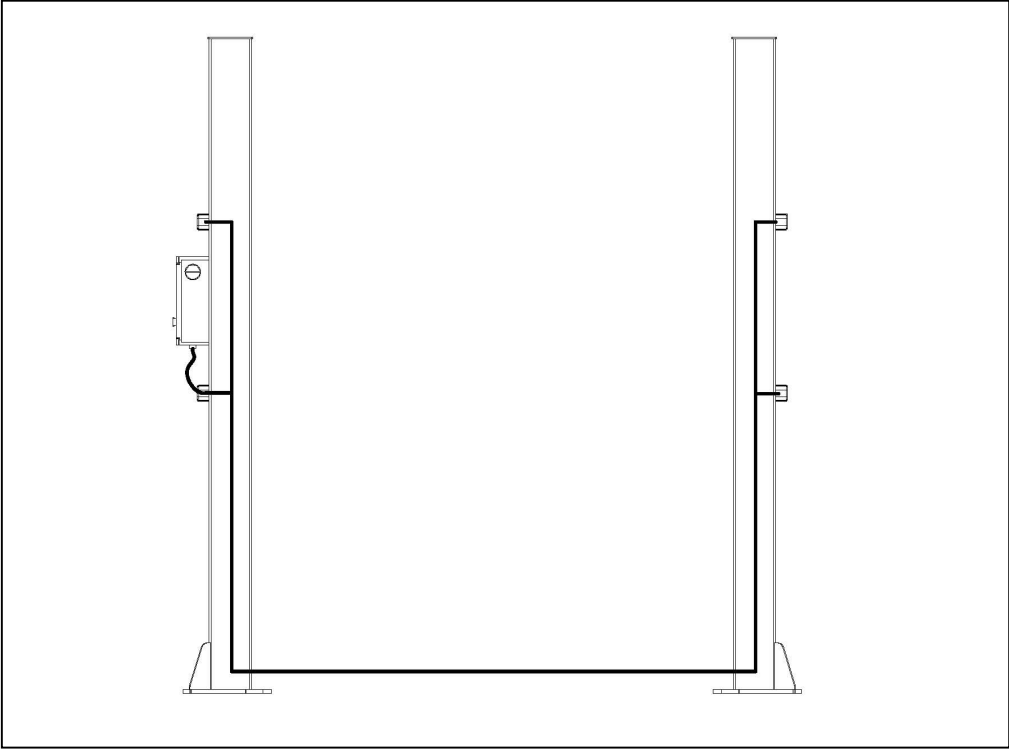

Annex4, Wiring diagram

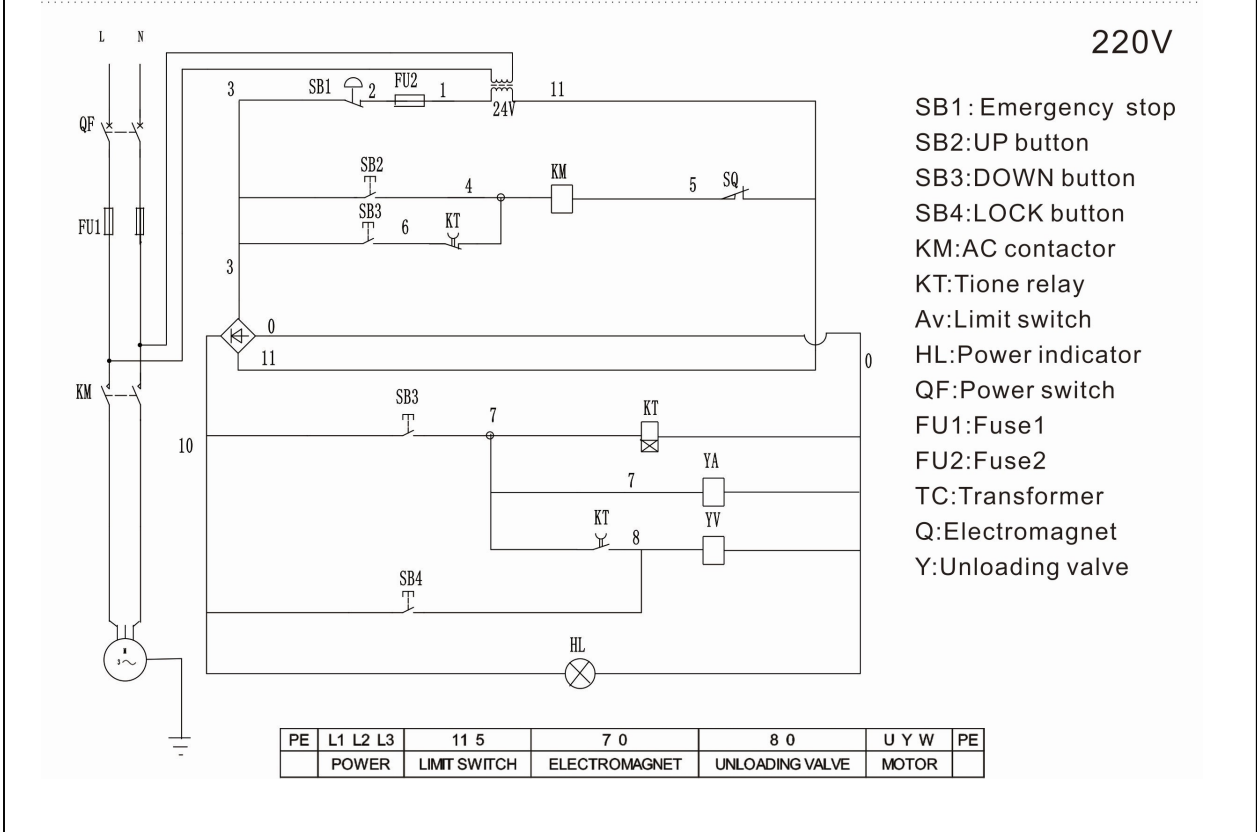
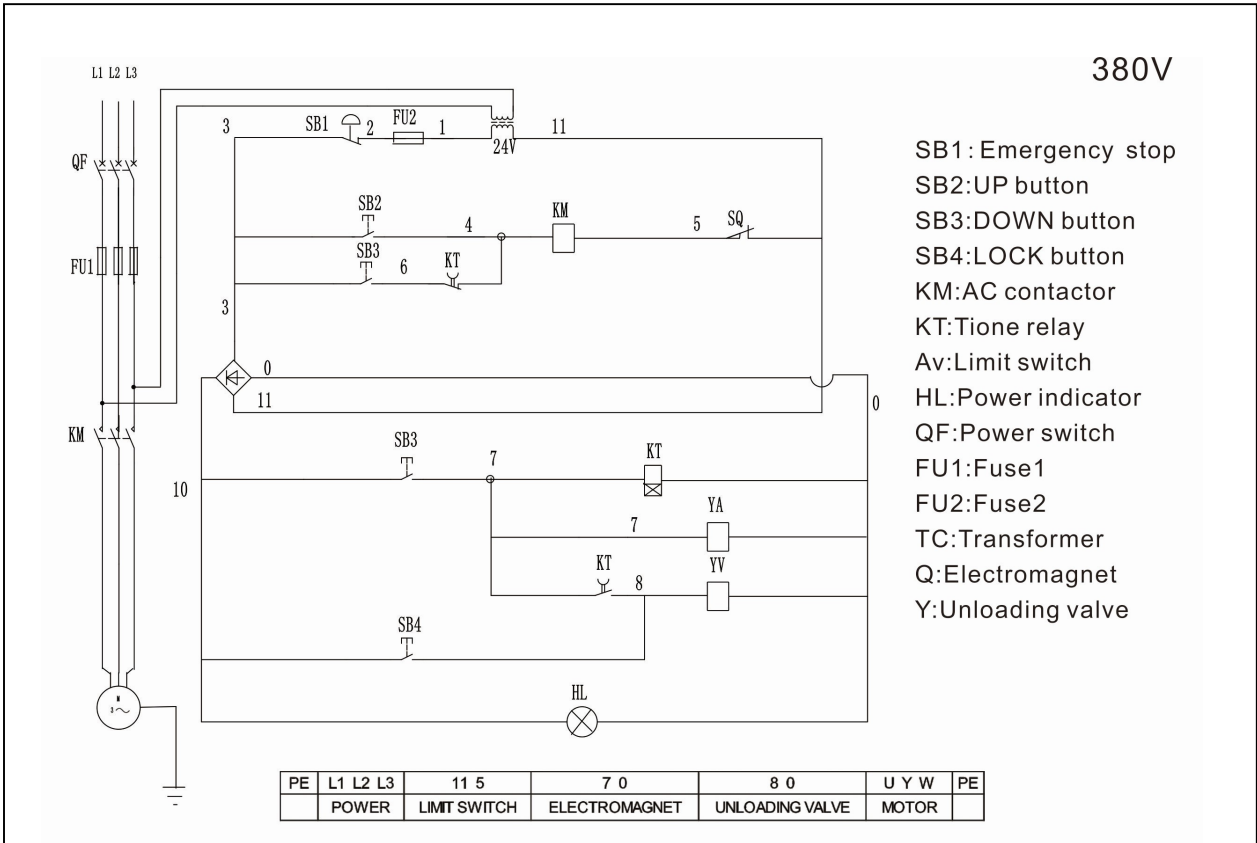

Annex 5, Assembly drawings

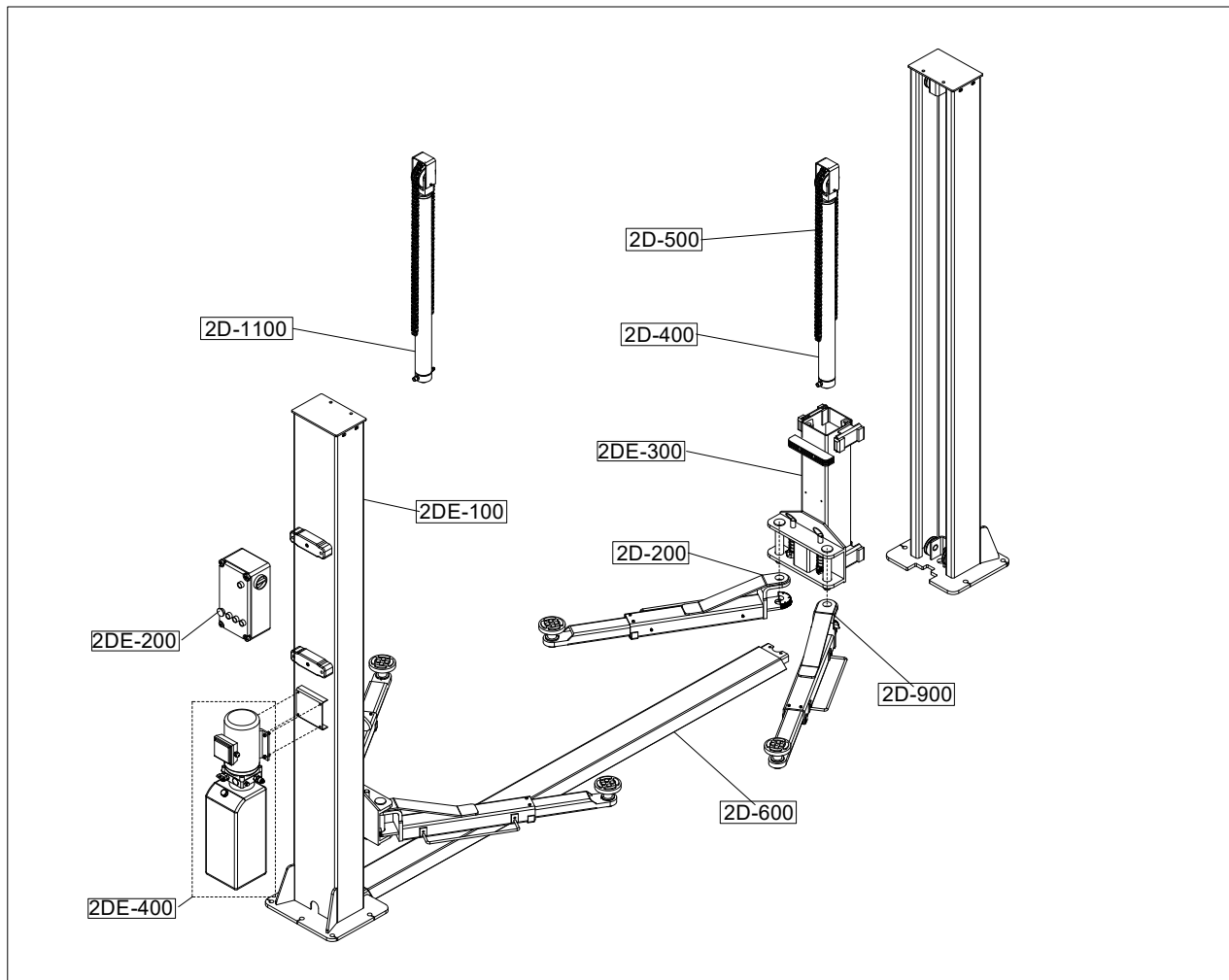

S/N	Name	Qty
2DE-100	Complete column assembly	2set
2D-200	Complete lifting arm assembly	2set
2DE-300	Complete carriage assembly	2set
2D-400	Complete slave oil cylinder	1set
2D-500	Chain	2pc
2D-600	Base plate	1pc
2DE-400	Complete power unit assembly	1set
2DE-200	Complete control box assembly	1set
2D-900	Complete lifting arm assembly	2set
2D-1100	Complete master oil cylinder	1set

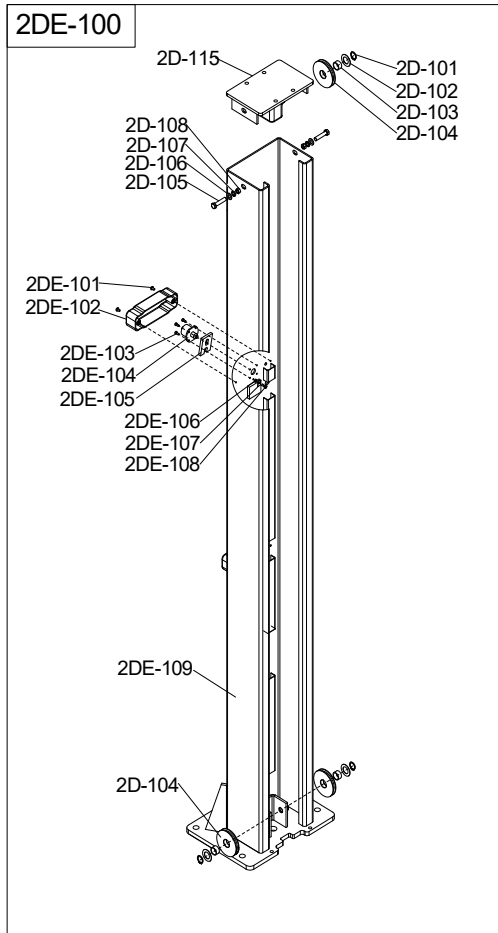

S/NN	Name	Qty
2D-101	Shaft snap ring $\varnothing 25$	6 pc
2D-102	Large flat washer $\varnothing 25$	6 pc
2D-104	Pulley $\varnothing 108*25$ mm	4 pc
2D-105	Hex screw M12*25	8 pc
2D-106	Spring washer $\varnothing 12$	8 pc
2D-107	Flat washer $\varnothing 12$	8 pc
2D-108	Hex nut M12	8 pc
2D-109	Cross round head cap screw M4*25	2 pc
2D-110	Top limit switch ME8104	1 pc
2DE-101	Cross pan head screw M6*8	8 pc
2DE-102	Insurance cover	4 pc
2DE-103	Hex socket head cap screw M5*10	16 pc
2DE-104	Electromagnet	4 pc
2DE-105	Electric insurance plate	4 pc
2DE-106	Fixed sleeve	4 pc
2DE-107	Fixed plate	4 pc
2DE-108	Cross pan head screw M6*10	4 pc
2DE-109	Column	2 pc
2D-115	Top plate	2 pc

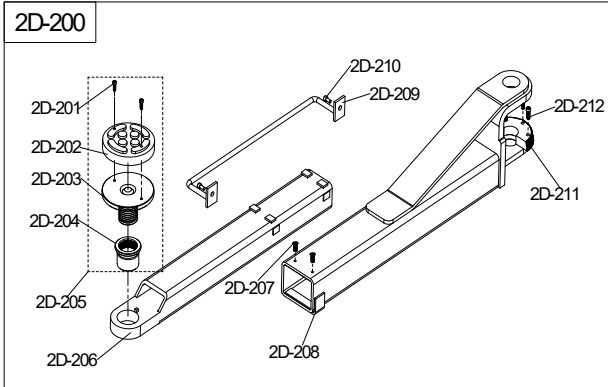

S/NN	Name	Qty
2D-201	Cross countersunk head screw	8 pc
2D-202	Rubber lifting pad 120*30mm	4 pc
2D-203	Lifting tray	4 pc
2D-204	Swivel nut	4 pc
2D-205	Complete tray assembly (2C-201,202,203,204)	4 set
2D-206	Lifting arm1	1 pc
2D-207	Cross socket head cap screw M8*12	8 pc
2D-208	Lifting arm2	2 pc
2D-209	Fender	4 pc
2D-210	Hex socket head cap screw M8	8 pc
2D-211	Semi-circle block	4 pc
2D-212	Hex socket head cap screw M8*12	12 pc
2D-213	Rubber pad	2 pc
2D-901	Lifting arm3	2 pc
2D-902	Lifting arm4	1 pc

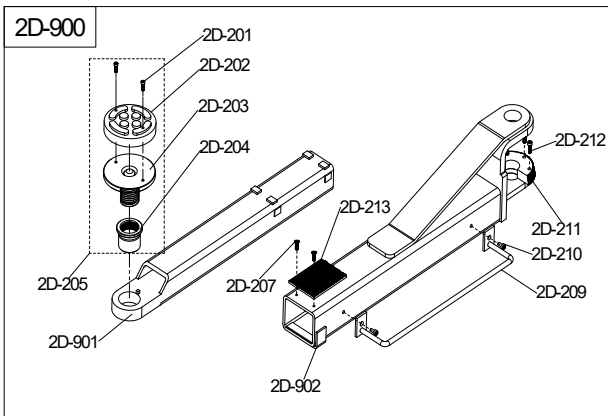

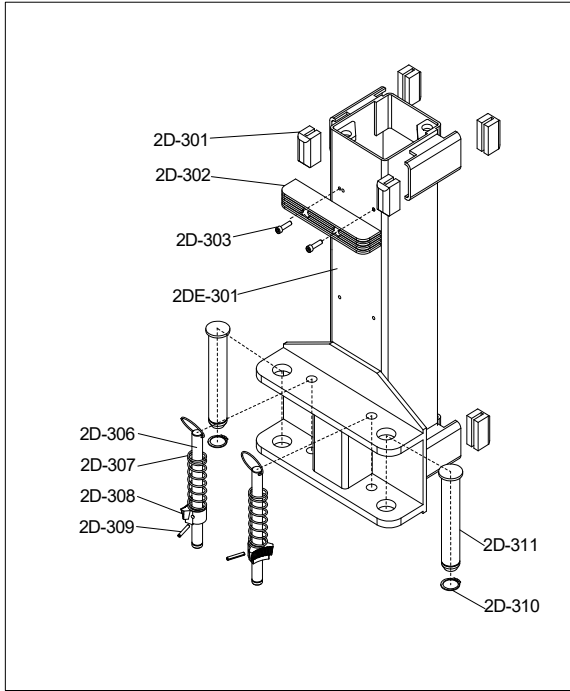

S/NN	Name	Qty
2D-301	Slider	16 pc
2D-302	Protection rubber pad	2 pc
2D-303	Cross flat head cap screw M8	4 pc
2D-304	Carriage	2 pc
2D-306	Lifting arm insurance rod \varnothing 22 (included the key ring \varnothing 4*60)	4 pc
2D-307	Spring	4 pc
2D-308	Teeth block	4 pc
2D-309	Elastic cylindrical pin	4 pc
2D-310	Shaft snap ring \varnothing 40	4 pc
2D-311	Pin shaft	4 pc

2D-400

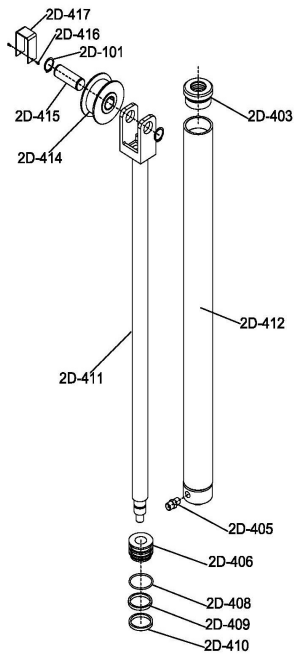

2D-1100

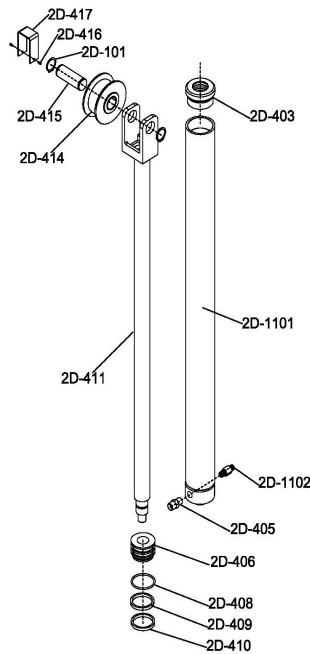

S/NN	Name	Qty
2D-403	Oil cylinder cover	2pc
2D-405	Oil hose connector	1pc
2D-1102	Oil hose connector	2pc
2D-406	Piston	2pc
2D-408	O-ring 63*5.7mm	2pc
2D-409	Guided ring 63*58*10mm	2pc
2D-410	Y-ring 63*48*10mm	2pc
2D-411	Piston rod	2pc
2D-412	Slave oil cylinder	1pc
2D-414	Chain wheel	2pc
2D-415	Shaft	2pc
2D-101	Shaft snap ring \varnothing 30	4pc
2D-416	Hex socket head cap screw M8*16	4pc
2D-417	Retaining plate	2pc
2D-418	Complete seal rings(including	2set
2D-1101	Master oil cylinder	1pc

2DE-400

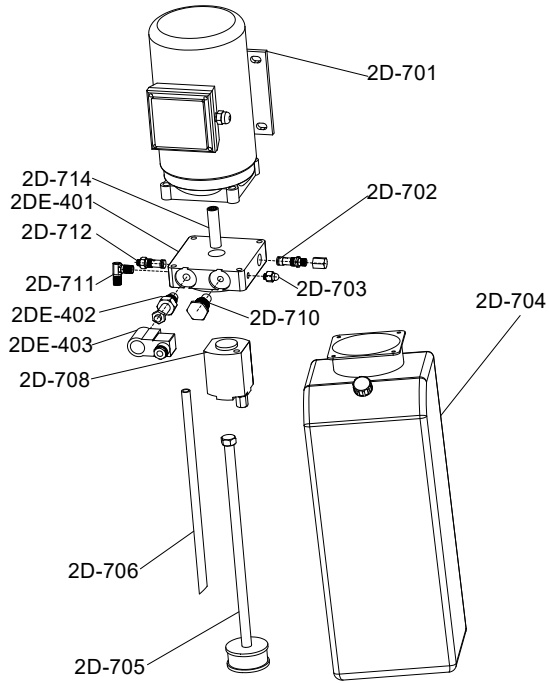

S/N	Name	Qty
2D-701	Motor	1 pc
2D-702	Overflow valve	1 pc
2D-703	Plug	1 pc
2D-704	Plastic oil tank	1 pc
2D-705	Oil absorbing pipe	1 pc
2D-706	Oil back pipe	1 pc
2DE-403	Solenoid valve	1 pc
2D-708	Gear pump	1 pc
2DE-402	Unloading valve	1 pc
2D-710	One-way valve	1 pc
2D-711	Oil hose connector	1 pc
2D-712	Throttle valve	1 pc
2DE-401	Valve seat	1 pc
2D-714	Annectent spinde	1 pc

steel cable connection drawing

S/N	Name	Qty
2D-117	Steel cable	2 pc

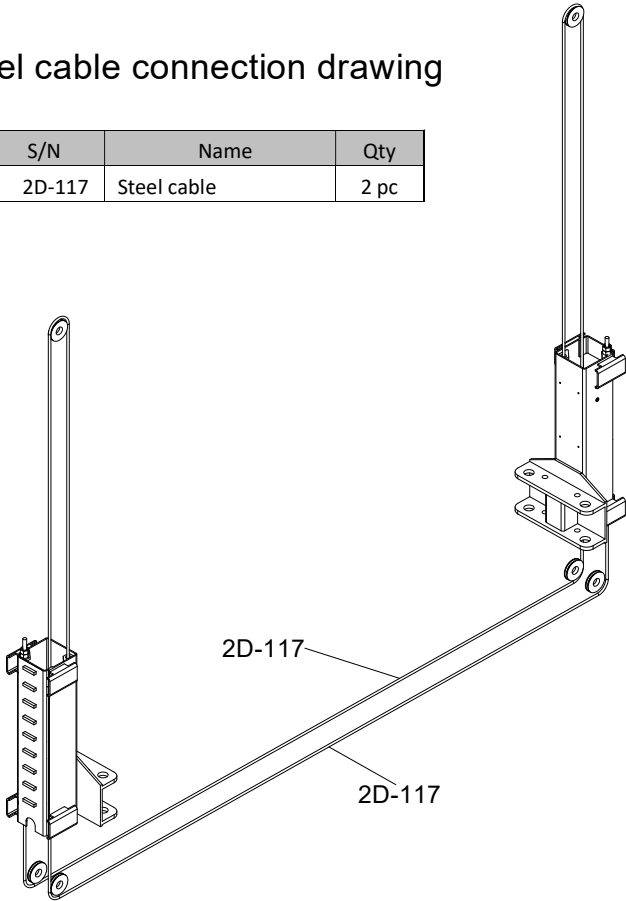

oil hose connection drawing

S/N	Name	Qty
2D-601	Short oil hose	1 pc
2D-602	Long oil hose	1 pc

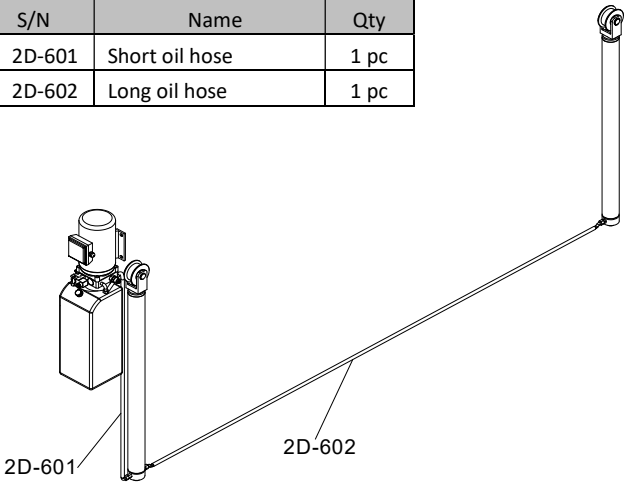

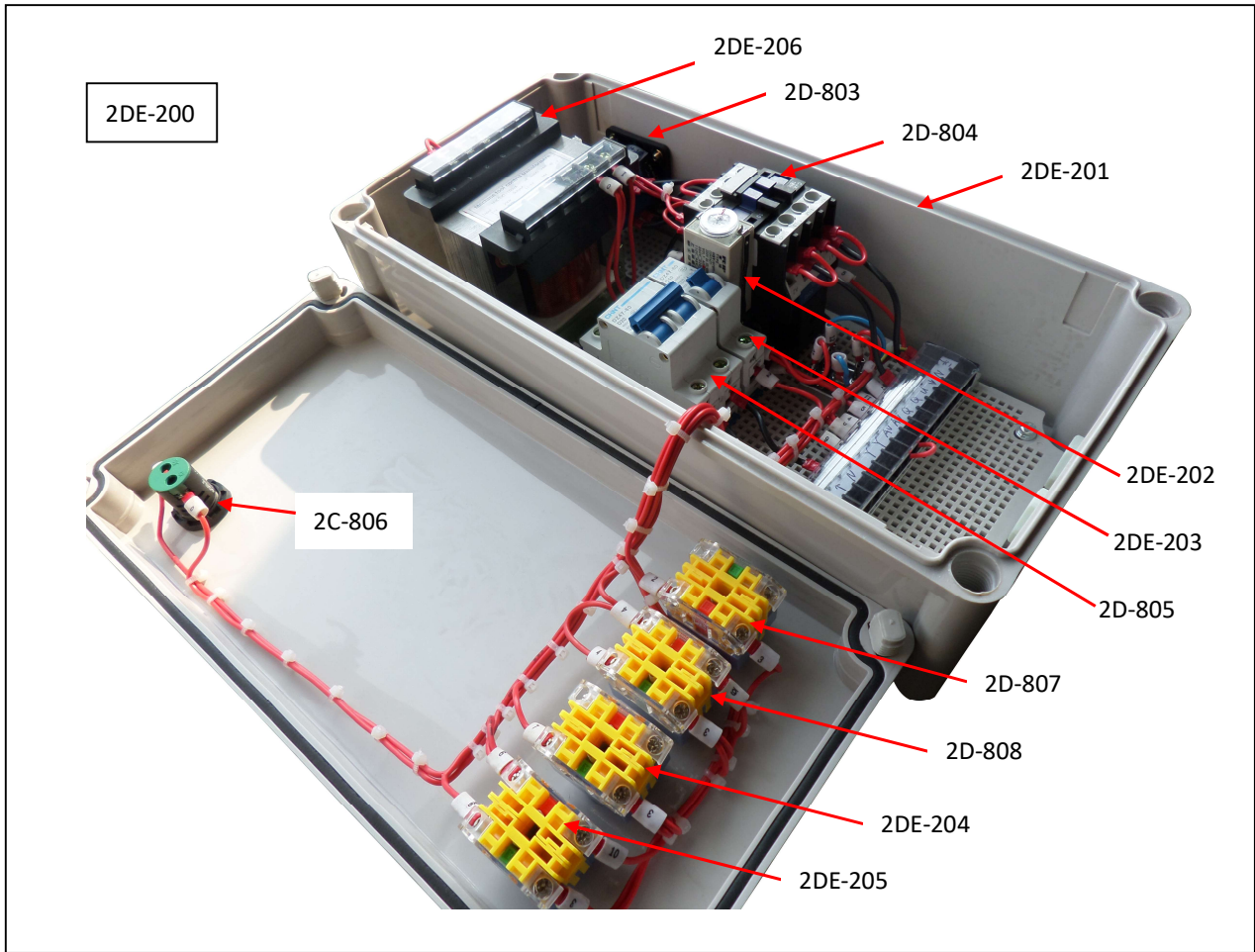

S/N	Name	Spec.	Qty
2DE-201	Control box shell		1 pc
2DE-206	Transformer		1 pc
2D-803	Power switch	LW26GS-20-04-1	2 pc
2D-804	AC contactor	CJX2-1810/24V	1 pc
2D-805	Circuit breaker (230V)	DZ47-60	1 pc
2D-806	Power indicator	AD16/24V	1 pc
2D-807	Emergency switch		1 pc
2D-808	Button (up)	LAY37	1 pc
2DE-202	Time relay		1 pc
2DE-203	Circuit breaker		1 pc
2DE-204	Button (down)		1 pc
2DE-205	Button (lock)		1 pc