

N.30 CARGO SHORT H

*with pickup bed 1150x1240x250 mm

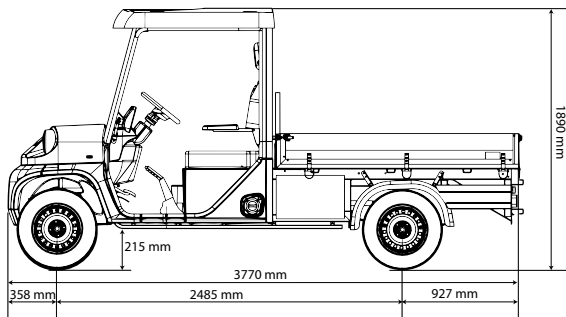
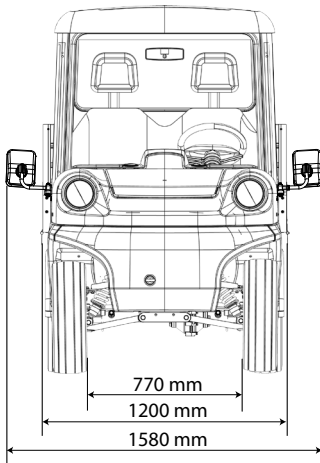

N.30 CARGO LONG H

*with pickup bed 1750x1240x250 mm

	CARGO SHORT	CARGO LONG
MOTOR	5,0 kW / 8,0 kW AC	5,0 kW / 8,0 kW AC
NOMINAL POWER	5,0 kW / 8,0 kW	5,0 kW / 8,0 kW
PEAK POWER	11,5 kW / 14 kW	11,5 kW / 14 kW
MAX TORQUE	75 Nm / 60Nm	75 Nm / 60Nm
MOTOR CONTROLLER	350A / 450A	350A / 450A
CHASSIS	Hot dip galvanized steel frame	Hot dip galvanized steel frame
BRAKES	Hydraulic brakes - disc (F) & drum (R)	Hydraulic brakes - disc (F) & drum (R)
SUSPENSIONS	Double wishbone (F) - Leaf spring(R)	Double wishbone (F) - Leaf spring(R)
TIRES	165 R13	165 R13
TOW LOAD CAPACITY	260 kg	275 kg

PERFORMANCE

TOP SPEED	43 km/h
------------------	---------

MASS

CHASSIS PAYLOAD	up to 500 kg	up to 1000 kg
VEHICLE WEIGHT (without battery and options)	550 kg	515 kg

DIMENSIONS

LENGTH*	3150 mm	3770 mm
WIDTH (with / without mirrors)	1200 mm / 1580 mm	1200 mm / 1580 mm
HEIGHT	1890 mm	1890 mm
WHEELBASE	1900 mm	2485 mm
OUTER TURNING RADIUS	8000 mm	9400 mm

PICKUP BED OPTIONS length x width x height - material

1150 x 1240 x 250 mm - profiled alu	1750 x 1240 x 250 mm - profiled alu
1150 x 1240 x 350 mm - profiled alu	1750 x 1240 x 350 mm - profiled alu
1150 x 1240 x 250 mm - steel plate	1750 x 1240 x 250 mm - steel plate
	1850 x 1310 x 250 mm - profiled alu
	1850 x 1310 x 350 mm - profiled alu
	2050 x 1400 x 250 mm - profiled alu
	2050 x 1400 x 350 mm - profiled alu

STANDARD FEATURES

Automatic electromagnetic brake, 7-inch touch screen display, on-board diagnostics, 48V on-board battery charger, steering column mounted front & reverse (F-N-R) selector switch, LED front & rear lights, 12V output + USB charging socket, windshield with wipers, 3x cupholders, 4x storage nets in cabin, 3-point seat belts

OPTIONAL FEATURES

8,0 kW drive motor, water filling system for Flood Lead Acid (FLA) batteries, doors, power steering, tilt system, power steering, mesh cages, frame structure with a canvas cover, heated front windshield, heater – diesel or electric, FM or DAB radio with Bluetooth, profiled seats, reverse camera, tow hook, forward drive warning sound or AVAS system (Acoustic Vehicle Alerting System), beacons & flashing warning lights, roof bars, bumper

BATTERY	SHORT & LONG FLA	SHORT & LONG LI-ION		
CAPACITY	T145 260Ah	6,2 kWh	9,3 kWh	12,4 kWh
VOLTAGE	48 V	48 V	48 V	48 V
WEIGHT	270 kg	38 kg	57 kg	76 kg
CHARGE TIME	~11 h	~4,5 h	~6,5 h	~9,5 h