

12 TON SHOP PRESS

ITEM NO. TY12001

OWNER'S MANUAL & OPERATING INSTRUCTIONS

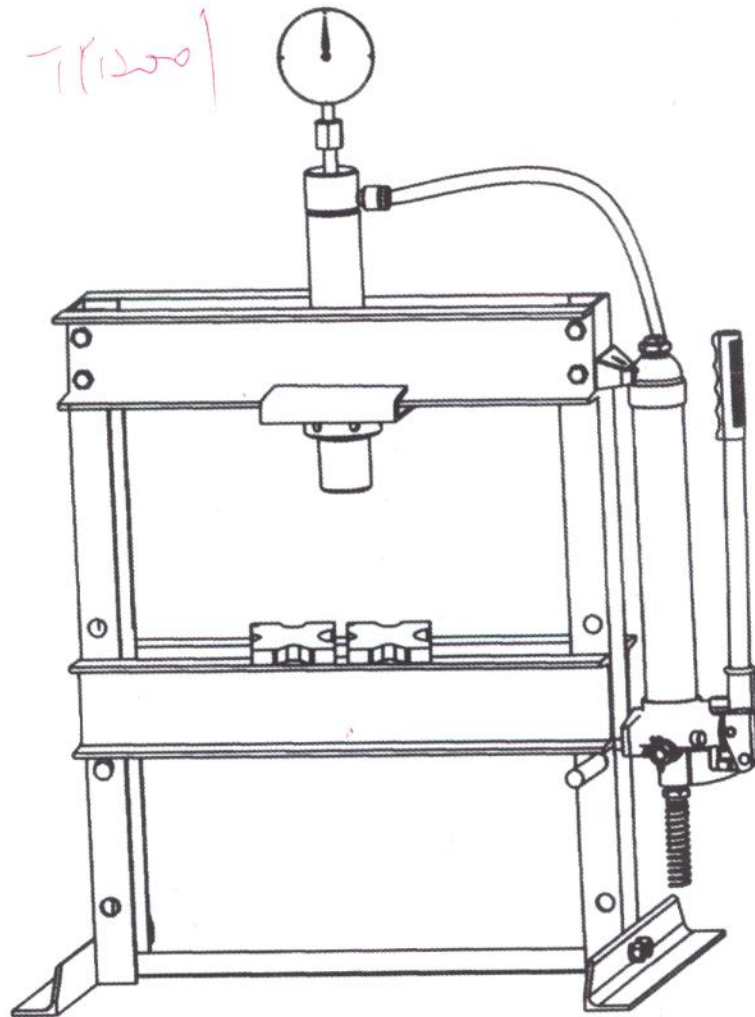

PARTS LIST

SHOP PRESS PARTS LIST (figure a)

Part	Description	Q'ty	Part	Description	Q'ty
01	Nut M12	4	16	Lock Washer 12	8
02	Lock Washer 12	4	17	Nut M12	8
03	Washer	4	18	Upper Crossbeam	2
04	Base Section	2	19	Under Plate	1
05	Post	2	20	Ram Assy	1
06	Lower	1	21	Pressure Gauge	1
07	Bolt M12x35	4	22	Bolt M8x16	1
08	Bed Frame Pin	2	23	Bolt M6x16	1
09	Prese Bed Frame	1	24	Lock Washer 6	1
10	Heel Black	2	25	Under Round Nut	1
11	Bolt M8x16	1	26	Under Round Nut	1
12	Lock Washer 8	1	27	Connection Nut	1
13	Pump Assy	1	28	Hoss Fitting	1
14	Bolt M12x35	8	29	Gauge Connection Nut	1
15	Washer 12	8			

RAM PARTS LIST (figure b)

Part	Description	Q'ty	Part	Description	Q'ty
R01	Bolt M20x25	1	R14	Busting	1
R02	Gauge Connection Nut	1	R15	O-ring 46.5x1.5	1
R03	Rectagle ring	1	R16	Sping	1
R04	Gauge Coup ler	1	R17	Bolt M8x40	1
R05	Cylinder	1	R18	Nut M6	1
R06	Dust Cop	1	R19	Nut	1
R07	Cop ler and Connecton Nut	1	R20	Upper Round Nut	1
R08	Bolt M5x20	1	R21	Under Round Nut	1
R09	Steel Wire ring	1	R22	Ram	1
R10	Ring	1	R23	Steel Wire ring	1
R11	O-ring 40x5.3	1	R24	Rectagle ring	1
R12	See ling Ring	1	R25	Bolt M6x12	1
R13	O-ring	1	R26	Toe	1

SHOP PRESS PARTS LIST (a)

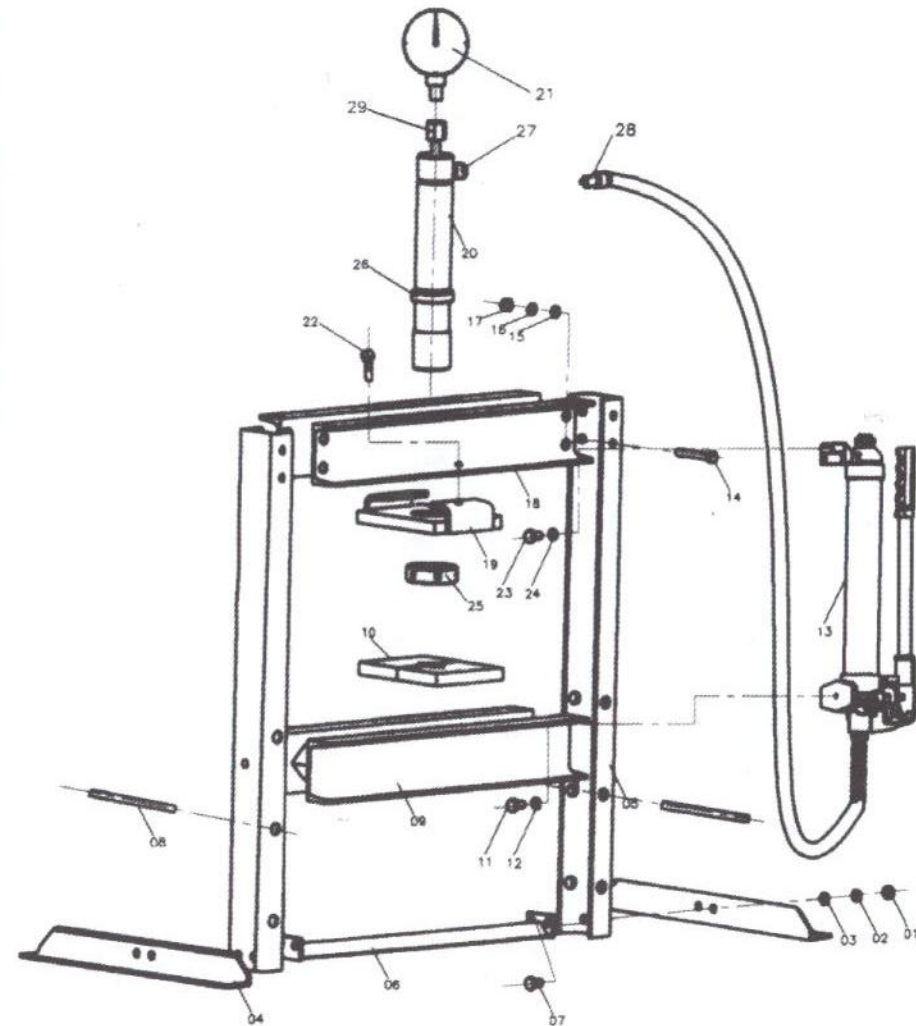

RAM PARTS LIST (b)

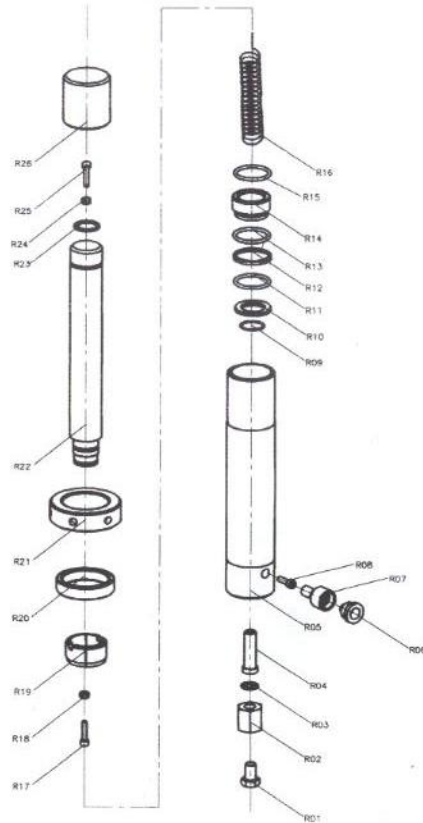

ASSEMBLY INSTRUCTIONS

Use the exploded drawing as your guide to assemble. Lay all parts and assemblies out in front of you before beginning. The following procedure is recommended:

- Attach one base section (04) to left post and lower cross member (06) using bolts (07), washers (03), lock washers (02) and nuts (01), then attach another to right post and the lower cross member.
- Put the press frame in an upright position, attach one upper cross beam (18) to left and right posts (05) using bolts (14), washers (15), lock washers (16) and nuts (17).
- Put another upper crossbeam into position and insert the under plate(19) to the two upper cross beams at the same time, then secure this cross beam to the posts using bolts (14), washers (15), lock washers (16) and nuts (17).
- Screw the upper round nut (26) onto the ram (20), insert the ram into the hole in the under plate (19), then screw the under round nut (25) onto the ram and

ASSEMBLY (continued)

- Insert bed frame pin (08) into the holes in the posts, then insert the joined press bed frame (09) into press frame and onto bed frame pin.
- Connect the hydraulic hose fitting (28) to the connection nut (27) and assemble the pressure gauge (21) to the pressure gauge connection nut (29) which is on the top of ram (20).
- Tighten all bolts and screws.

BEFORE FIRST USE

- a) Before first use of this product, purge away air from the hydraulic system: open the release valve by turning it counterclockwise. Pump several full strokes to eliminate any air in the system.
- b) Check all parts and conditions, if there is any part broken, stop using it and contact your supplier immediately.

OPERATING INSTRUCTIONS

WARNING! ENSURE THAT YOU READ, UNDERSTAND AND APPLY THE SAFETY INSTRUCTIONS AND WARNINGS BEFORE USE.

- Place the heel block on press bed frame, then insert workpiece onto the heel block.
- Close the release valve by turning it clockwise until it is firmly closed.
- Pump the handle until serrated saddle nears workpiece.
- Align workpiece and ram to ensure center-loading.
- Pump the handle to apply load onto workpiece.
- When work is done, stop pumping the handle, slowly and carefully remove load from workpiece by turning the release valve counterclockwise in small increments.
- Once ram has fully retracted, remove workplace from bed frame.

MAINTENANCE

- Clean the outside of the press with dry, clean and soft cloth and periodically lubricate the joints and all moving parts with a light oil as needed.
- When not in use, store the press in a dry location with ram and piston fully retracted.
- When press efficiency drops, purge always air from hydraulic system as described before.
- Check the hydraulic oil; remove the oil filler nut on the top of the reservoir, if the oil is not adequate, fill with high quality hydraulic jack oil as necessary, then replace the oil filler nut, purge away air from the hydraulic system.

SAFETY INSTRUCTIONS

PLEASE READ THESE INSTRUCTIONS CAREFULLY. NOTE THE SAFETY INSTRUCTIONS AND WARNINGS. USE THE PRODUCT CORRECTLY AND WITH CARE FOR THE PURPOSE OF WHICH IT IS INTENDED. FAILURE TO DO SO MAY CAUSE DAMAGE TO PROPERTY AND/OR SERIOUS PERSONAL INJURY. PLEASE KEEP THIS INSTRUCTION MANUAL SAFE FOR FUTURE USE.

We've done all we can to assure this press offers the outmost in safety, but you have to do your part. No amount of warning can take the place of your good judgment, so make sure it's the first thing you bring to any job. Beyond that here are some obvious tips:

- Steel and others materials can shatter, so always use protective eye-wear that complies with the appropriate ANSI code.
- If you detect anything that may indicate imminent structural failure, stop using the press immediately and inspect it thoroughly.
- Bolt the press to the floor if it is to be used on bulky or unstable items.
- Do not use press to compress springs or any other item that could disengage and cause a potential hazard.
- Use a qualified person to maintain the press in good condition. Keep it clean for best and safest performance.
- Do not exceed the rated capacity. Never apply excessive force to a workpiece and always use the pressure gauge to accurately determine the applied load.
- Use this press for the purpose for which it is intended. DO NOT use it for any other purpose it is not designed to perform.
- Keep children and unauthorized persons away from the work area.
- Remove ill fitting clothing. Remove ties, watches, rings and other loose jewelry and contain long hair.
- Wear ANSI approved impact safety goggles, full-face impact safety shield and heavy-duty work gloves when operating the press.
- Keep proper balance and footing, do not over-reach and wear nonskid footwear.

SAFETY INSTRUCTIONS

- Only use this press on a surface that is stable, level, dry and not slippery, and capable of sustaining the load. Keep the surface clean, tidy and free from unrelated materials and ensure that there is adequate lighting.
- Inspect the press before each use. DO NOT use if bent, broken, cracked, leaking or otherwise damaged. Any suspect parts are noted or it has been subjected to a shock load.
- Check to ensure that all applicable bolts and nuts are firmly tightened.
- Ensure that workpiece is center-loaded and secure.
- Keep hands and feet away from bed area at all times.
- DO NOT use the shop press to compress spring or any other item that could disengage and cause a potential hazard. Never stand directly in front of loaded press and never leave loaded press unattended.
- DO NOT operate the press when you are tired or under the influence of alcohol, drugs or any intoxicating medication.
- DO NOT allow untrained persons to operate the press.
- DO NOT make any modifications to the press.
- DO NOT use brake fluid or any other improper fluid and avoid mixing different types of oil when adding hydraulic oil. Only good quality hydraulic jack oil can be used.
- DO NOT expose the press to rain or any other kind of bad weather.
- If the press needs repairing and/or there are any parts that need to be replaced, have it repaired by authorized technicians and only use the replacement parts supplied by the manufacturer.

WARNING! The warnings, cautions and instructions discussed in this manual cannot cover all conditions and situations that may occur. It must be understood by the operator that common sense and caution are factors which cannot be built into this product, but must be supplied by the operator.

⚠ WARNING!

- Only use this press on a surface that is stable, level, dry and not slippery, and capable of sustaining the load. Keep the surface clean, tidy and free from unrelated materials and ensure that there is adequate lighting.
- Inspect the press before each use. DO NOT use if bent, broken, cracked, leaking or otherwise damaged. Any suspect parts are noted or it has been subjected to a shock load.
- Check to ensure that all applicable bolts and nuts are firmly tightened.
- Ensure that workpiece is center-loaded and secure. Keep hands and feet away from bed area at all times.
- DO NOT use the shop press to compress spring or any other item that could disengage and cause a potential hazard. Never stand directly in front of loaded press and never leave loaded press unattended.
- DO NOT operate the press when you are tired or under the influence of alcohol, drugs or any intoxicating medication.
- DO NOT allow untrained persons to operate the press. DO NOT make any modifications to the press.
- DO NOT use brake fluid or any other improper fluid and avoid mixing different types of oil when adding hydraulic oil. Only good quality hydraulic jack oil can be used.
- DO NOT expose the press to rain or any other kind of bad weather.
- If the press needs repairing and/or there are any parts that need to be replaced, have it repaired by authorized technicians and only use the replacement parts supplied by the manufacturer.

READ, STUDY, AND UNDERSTAND ALL WARNINGS AND OPERATING INSTRUCTIONS.