

# PRO-Line Positioners

## Welding Positioner PRO 1

With 20 mm hollow shaft

### Features

- The turntable PRO 1 has a precise drive unit with face-plate that is mounted on a stable floor stand.
- The tilting bracket offers the possibility to put the work-piece via a tilting range of 0° – 90° into the required welding position.
- The rotary motion occurs via a direct current gearmotor with worm gear and is infinitely adjustable.
- Table diameter: 300 mm. The surface is chrome-plated as a protection against weld spatters.
- The control panel is easy to understand and operate.
- Start/stop via location-independent foot switch.
- Adjustment of turning speed and rotating direction directly via the machine.
- HF-protected.

**THE HOUSING OF THE TURNTABLE MUST BE CONNECTED DIRECTLY TO THE HOUSE GROUND!**

Model	PRO 1
Supply voltage	AC 230 V/50 Hz
Ground connection	300 A/100 %
Tilting range	0° – 90°
Table diameter	300 mm
Hollow shaft	20 mm
Mounting hole circle Ø	110mm to max. 264 mm
Slot width turntable	14 mm
Speed	A: 0,2 – 2 rpm B: 1,2 – 12 rpm
Rotating directions	cw/ccw
Max. load A	100 kg
Measurem. (L x W x H) mm	480 x 325 x 470
Weight	50 kg
Item no.	02.30.01.10020

### Note

suitable for Three-jaw Chuck 160D and Chuck 200D



### Scope of delivery:

- 1 Control system (integrated)
- 1 Foot switch



# PRO-Line Positioners

## Welding Positioner PRO 1

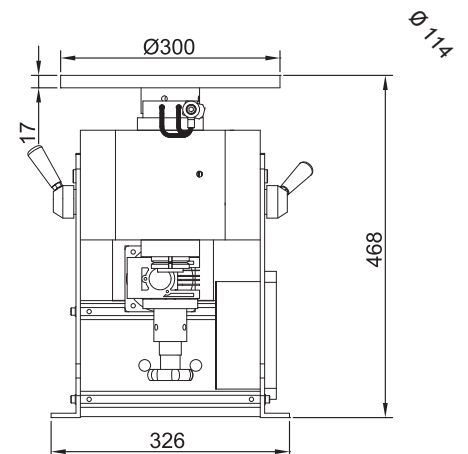
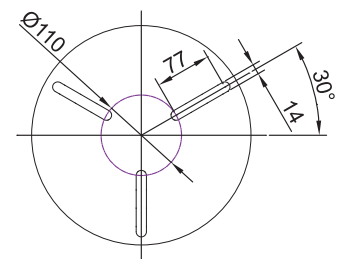
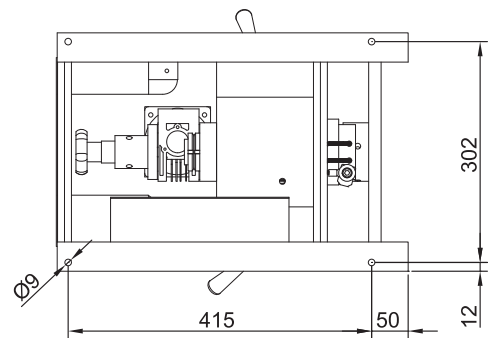
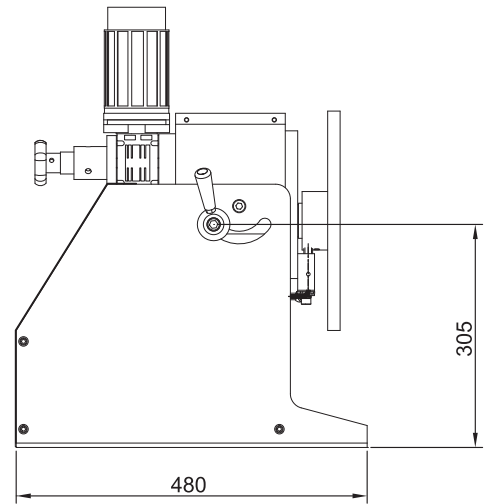
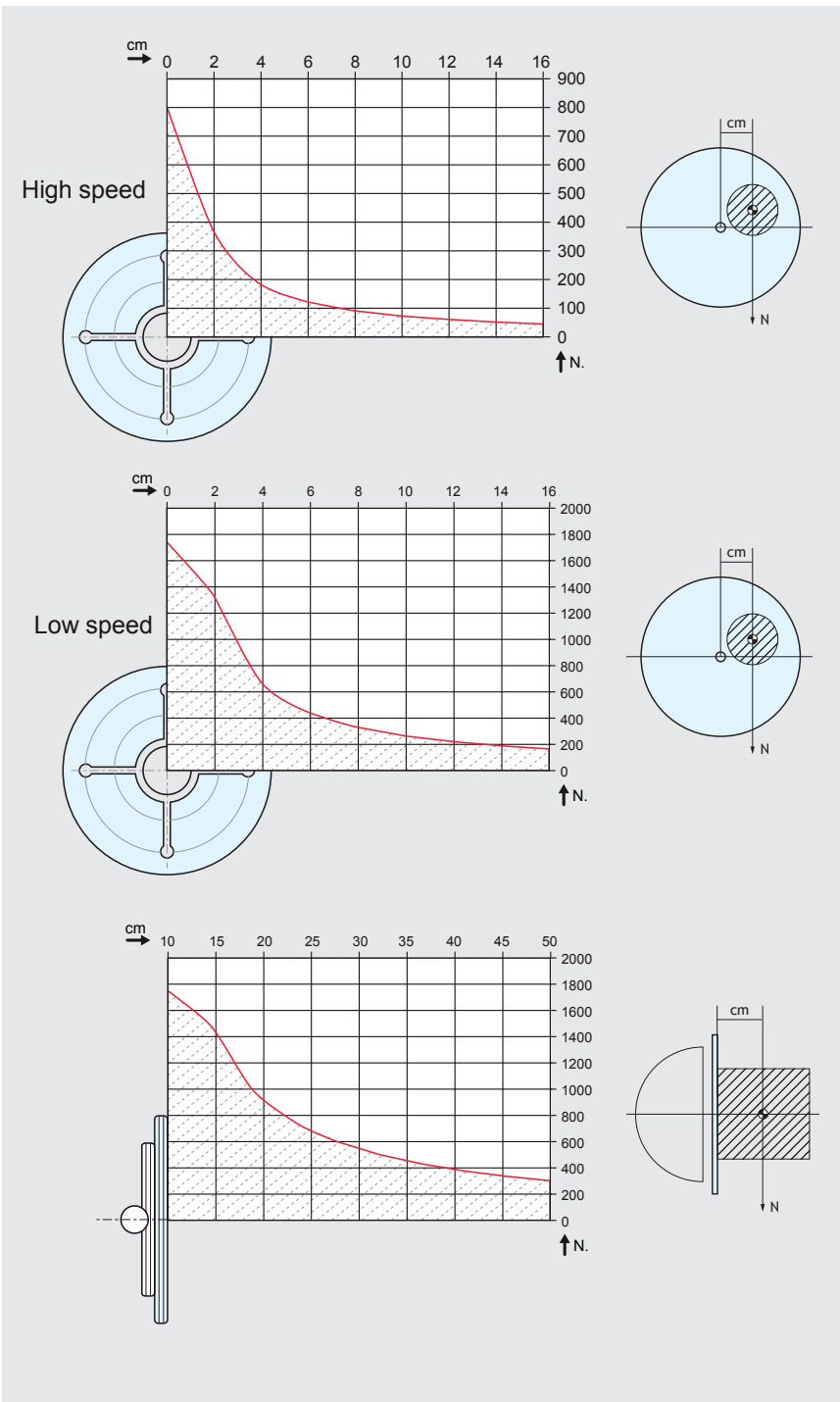

When choosing your positioner, please consider

- the center of gravity of your workpiece
- the weight of your tensioning device (chuck)